

FREIO PNEUMÁTICO DE BAIXA INÉRCIA SÉRIE PWBI / KKB COM REFRIGERAÇÃO POR ÁGUA

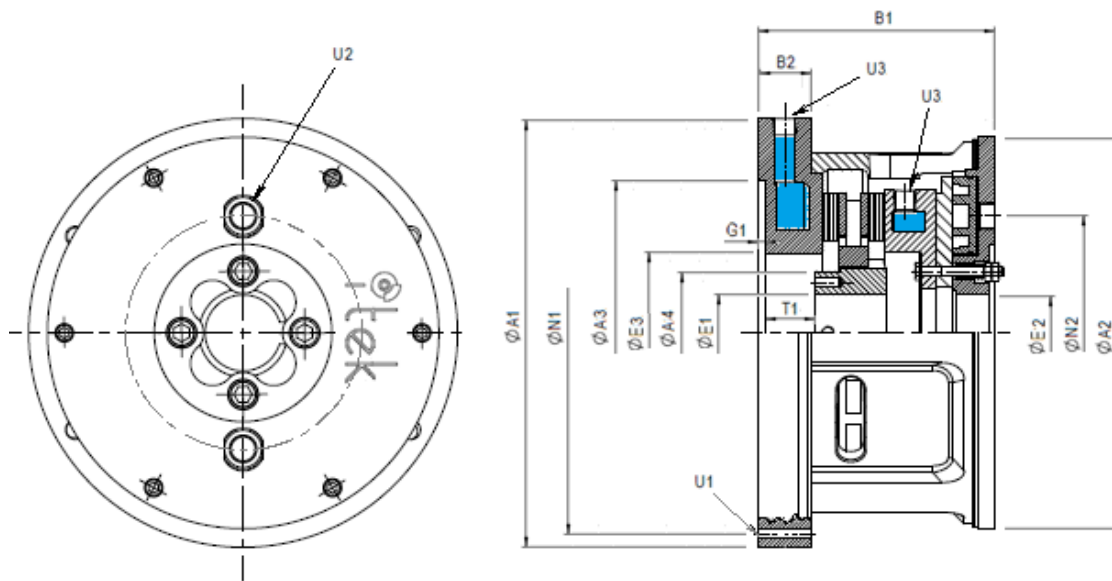

| Tamanho | Torque Est. c/ 0,2 bar (Nm) | Torque Est. c/ 5 bar (Nm) | Rot. Max. (RPM) | Dissip. Térmica Cont. (kW) | Dissip. Térmica Intermit. (kW) | Vazão da Água (L/min) | Peso Apr. (Kg) | A1 | A2 | A3 H8 | A4 | B1 | B2 | Min. E1 H7 | Max. E1 H7 | E2 | E3 | G1 | N1 | N2 | U1 | U2 | U3 | T1 |
|---------|-----------------------------|---------------------------|-----------------|----------------------------|--------------------------------|-----------------------|----------------|-----|-----|-------|-----|-----|----|------------|------------|----|-----|----|-----|-----|----------|-------------|-------------|----|
| 106 | 6 | 300 | 1.080 | 7 | 8 | 3 | 21 | 220 | 224 | 190 | 68 | 145 | 32 | 19 | 45 | - | 80 | 3 | 203 | 120 | 4 x Ø9 | 2 x 1/2"NPT | 2 x 1/2"NPT | 19 |
| 206 | 12 | 600 | 1.080 | 9 | 12 | 5 | 31 | 220 | 224 | 190 | 68 | 198 | 32 | 19 | 45 | - | 80 | 3 | 203 | 120 | 4 x Ø9 | 2 x 1/2"NPT | 2 x 1/2"NPT | 33 |
| 108 | 10 | 500 | 780 | 10 | 13 | 5 | 36 | 310 | 283 | 220 | 90 | 172 | 38 | 32 | 57 | - | 118 | 6 | 280 | 168 | 4 x Ø14 | 2 x 1/2"NPT | 2 x 1/2"NPT | 29 |
| 208 | 20 | 1.000 | 780 | 14 | 16 | 8 | 50 | 310 | 283 | 220 | 90 | 238 | 38 | 32 | 57 | - | 118 | 6 | 280 | 168 | 4 x Ø14 | 2 x 1/2"NPT | 2 x 1/2"NPT | 29 |
| 111 | 25 | 1.200 | 580 | 14 | 16 | 10 | 78 | 400 | 375 | 295 | 102 | 188 | 38 | 38 | 65 | - | 147 | 6 | 375 | 216 | 4 x Ø18 | 2 x 1/2"NPT | 2 x 1/2"NPT | 19 |
| 211 | 50 | 2.400 | 580 | 22 | 27 | 16 | 90 | 400 | 375 | 295 | 102 | 241 | 38 | 38 | 65 | - | 147 | 6 | 375 | 216 | 4 x Ø18 | 2 x 1/2"NPT | 2 x 1/2"NPT | 19 |
| 114 | 100 | 1.500 | 510 | 15 | 21 | 16 | 125 | 470 | 445 | 370 | 140 | 216 | 45 | 50 | 90 | - | 211 | 6 | 445 | 273 | 6 x Ø18 | 2 x 1/2"NPT | 2 x 1/2"NPT | 27 |
| 214 | 200 | 3.000 | 510 | 23 | 33 | 25 | 145 | 470 | 445 | 370 | 140 | 266 | 45 | 50 | 90 | - | 211 | 6 | 445 | 273 | 6 x Ø18 | 2 x 1/2"NPT | 2 x 1/2"NPT | 27 |
| 116 | 110 | 3.000 | 450 | 20 | 20 | 20 | 168 | 540 | 508 | 410 | 152 | 219 | 44 | 57 | 102 | - | 240 | 6 | 510 | 318 | 10 x Ø18 | 2 x 1/2"NPT | 2 x 1/2"NPT | 24 |
| 216 | 220 | 6.000 | 450 | 30 | 42 | 30 | 250 | 540 | 508 | 410 | 152 | 285 | 44 | 57 | 102 | - | 240 | 6 | 510 | 318 | 10 x Ø18 | 2 x 1/2"NPT | 2 x 1/2"NPT | 24 |
| 118 | 200 | 4.000 | 400 | 22 | 33 | 25 | 195 | 590 | 559 | 470 | 178 | 225 | 45 | 70 | 120 | - | 291 | 6 | 560 | 360 | 10 x Ø18 | 2 x 1/2"NPT | 2 x 1/2"NPT | 27 |
| 218 | 400 | 8.000 | 400 | 30 | 50 | 40 | 260 | 590 | 559 | 470 | 178 | 286 | 45 | 70 | 120 | - | 291 | 6 | 560 | 360 | 10 x Ø18 | 2 x 1/2"NPT | 2 x 1/2"NPT | 27 |
| 121 | 230 | 6.000 | 350 | 30 | 45 | 35 | 265 | 685 | 632 | 540 | 229 | 238 | 45 | 50 | 152 | - | 343 | 6 | 648 | 406 | 10 x Ø18 | 2 x 1/2"NPT | 2 x 1/2"NPT | 32 |
| 221 | 460 | 12.000 | 350 | 50 | 75 | 55 | 315 | 685 | 632 | 540 | 229 | 302 | 45 | 50 | 152 | - | 343 | 6 | 648 | 416 | 10 x Ø18 | 2 x 1/2"NPT | 2 x 1/2"NPT | 32 |
| 124 | 300 | 7.000 | 320 | 45 | 70 | 55 | 360 | 760 | 737 | 620 | 229 | 254 | 45 | 50 | 152 | - | 343 | 6 | 730 | 534 | 10 x Ø18 | 2 x 1/2"NPT | 2 x 1/2"NPT | 35 |
| 224 | 600 | 14.000 | 320 | 70 | 105 | 90 | 465 | 760 | 737 | 620 | 229 | 314 | 45 | 50 | 152 | - | 343 | 6 | 730 | 534 | 10 x Ø18 | 2 x 1/2"NPT | 2 x 1/2"NPT | 35 |
| 324 | 900 | 21.000 | 320 | 90 | 140 | 120 | 600 | 760 | 737 | 620 | 229 | 373 | 45 | 50 | 152 | - | 343 | 6 | 730 | 534 | 10 x Ø18 | 2 x 1/2"NPT | 2 x 1/2"NPT | 35 |
| 127 | 570 | 14.000 | 290 | 65 | 90 | 70 | 395 | 830 | 788 | 700 | 229 | 254 | 43 | 83 | 165 | - | 387 | 6 | 800 | 534 | 14 x Ø18 | 3 x 1/2"NPT | 2 x 1/2"NPT | 30 |
| 227 | 1140 | 28.000 | 290 | 100 | 140 | 110 | 560 | 830 | 788 | 700 | 229 | 307 | 43 | 83 | 165 | - | 387 | 6 | 800 | 534 | 14 x Ø18 | 3 x 1/2"NPT | 2 x 1/2"NPT | 30 |
| 130 | 1100 | 26.000 | 250 | 70 | 100 | 80 | 615 | 940 | 883 | 775 | 254 | 281 | 51 | 89 | 165 | - | 464 | 6 | 900 | 629 | 16 x Ø22 | 3 x 1/2"NPT | 2 x 1/2"NPT | 35 |
| 230 | 2200 | 52.000 | 250 | 105 | 165 | 130 | 935 | 940 | 883 | 775 | 254 | 422 | 51 | 89 | 165 | - | 464 | 6 | 900 | 629 | 16 x Ø22 | 3 x 1/2"NPT | 2 x 1/2"NPT | 49 |

Chaveta DIN 6885 | DIN 6886 | DIN 6887

SERIE TIPO TAMANHO

PWBI/KKB – 206

RESERVAMOS-NOS O DIREITO DE ALTERAR AS MEDIDAS SEM AVISO PRÉVIO

FEV 19



Parceiro Comercial
Speedy Usinagem
R. Radames Nardine 146
Mauá, SP

1: +55 (11) 96176-0956
e: info@itekbr.com
www.itekbr.com

