

EMBREGEM — PNEUMÁTICA

SÉRIE PEFI/EN

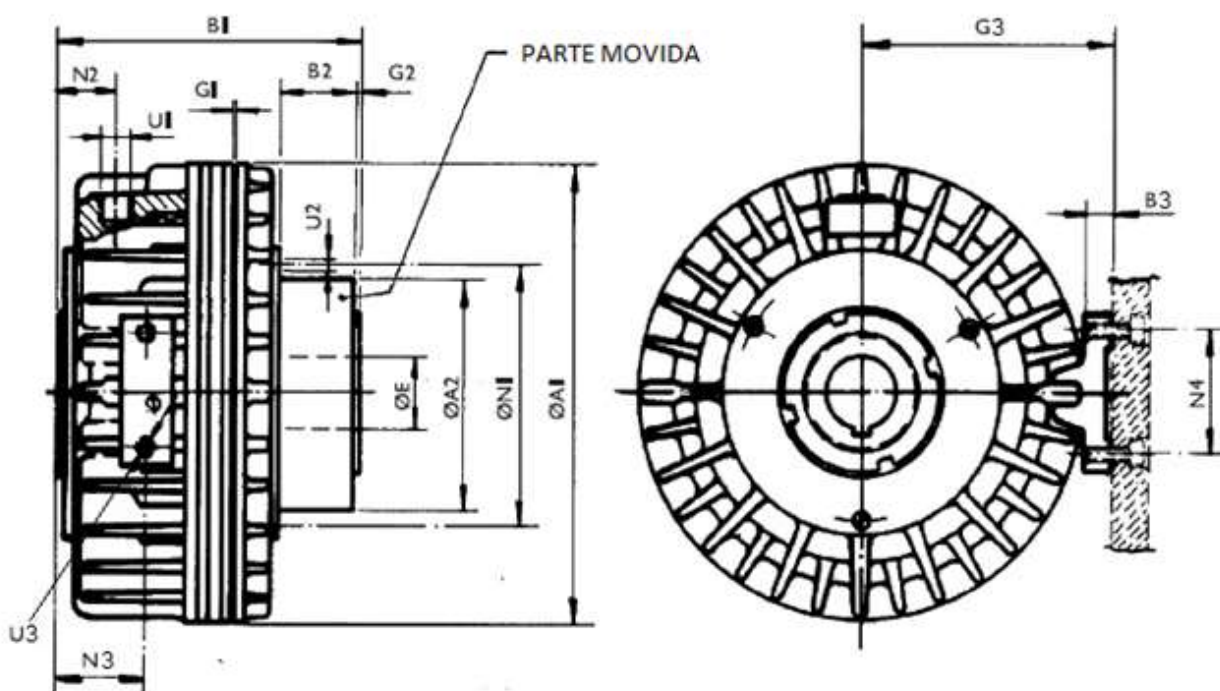

Tamanho	Torque Embreagem (Nm)	Rot. Max. (RPM)	Pressão (Bar)	A1	A2	B1	B2	B3	Min. E H7	Max. E H7	G2	G3	N1	N2	N3	N4	U1	U2	U3
01	17,5	2500	5,5	120	62	92	26	10	19	19	1	73	72	15	22	42	BSP 1/8"	6 x M5	M6
02	35	2000	5,5	150	74	102	26	10	24	25	1	87	85	17	26	42	BSP 1/4"	6 x M6	M6
03	70	1700	5,5	180	87	114	30	10	28	32	1	101	98	19	33	42	BSP 1/4"	6 x M6	M6
04	140	1500	5,5	216	102	126,5	32	13	38	42	1	123	115	23	33	50	BSP 3/8"	6 x M8	M8
05	280	1200	5,5	265	115	143	34	13	42	48	1	145	132	27,5	36	50	BSP 3/8"	6 x M10	M8
06	550	1000	5,5	320	140	163	40	13	55	60	1	172	160	27,5	45	50	BSP 1/2"	6 x M12	M8

Chaveta DIN 6885 | DIN 6886 | DIN 6887

SÉRIE TIPO TAMANHO

PEFI/EN – 06

RESERVAMOS-NOS O DIREITO DE ALTERAR AS MEDIDAS SEM AVISO PRÉVIO

JUN 18



Parceiro Comercial
Speedy Usinagem
R. Radames Nardine 146
Mauá, SP

t: +55 (11) 96176-0956
e: info@itekbr.com
www.itekbr.com

